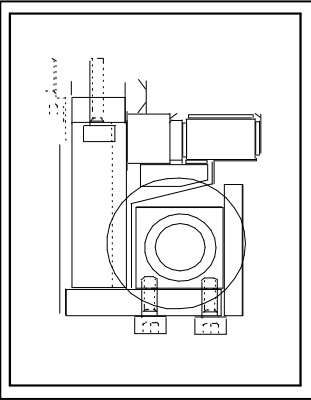
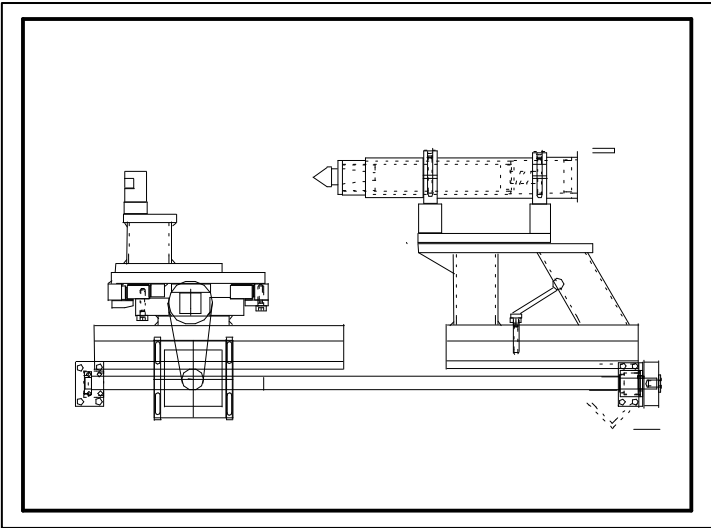
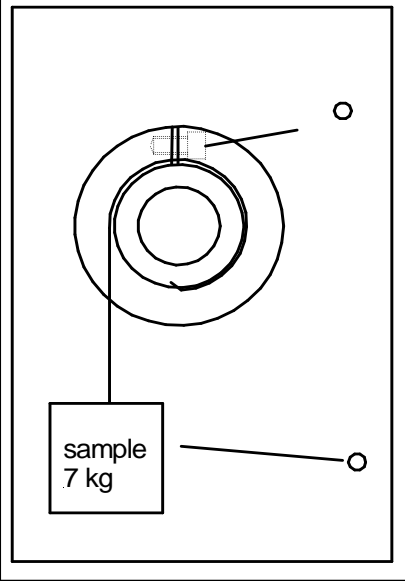

DE=	EN=	PT=	VN=			
<b>Kugelrollspindel 02</b>	<b>Ball Screw 02</b>	<b>Fusos de Esferas 02</b>	<b>Bóng vít 02</b>			
 <p>de= Bitte schauen Sie immer für eine korrekte Montage. Alle 3 Anschlüsse müssen in einer Linie sein. Toleranz ist sehr schwierig.</p> <p>en= Please look always for a right montage. All 3 connections must be in a same line. Tolerance is very difficult.</p> <p>pt= Por favor veja sempre para um certo montage. Todos os 3 conexões deve estar em um mesmo line. A tolerância é muito difícil.</p> <p>vn= Xin vui lòng xem luôn cho quyền montage. Tất cả 3 kết nối phải ở trong một cùng dòng. Khoan dung là rất khó khăn.</p> <p>de= Haupt sind die Führungen. Max. Sie ist etwa 0,03 mm von der Linie in beide Richtungen en= Chief are the guides. Max. out ist about 0.03 mm from the Line in both direction pt= Chefe são os guias. Max. fora ist cerca de 0,03 milímetros a partir da linha em ambos os sentidos vn= Trườg là người hướng dẫn. Max. ist ra khoảng 0,03 mm từ dòng trong cả hai hướng</p>	 <p>de= Bitte schauen Sie immer, dass die Kugelumlaufspindel in der gleichen Richtung wie die Führungen ist. Die Lehren sind haupt. Toleranz ist fast Null.</p> <p>en= Please look always that the ball screw is in the same direction like the guides. The gages are the Chief. Toleranz ist nearly like zero.</p> <p>pt= Por favor veja sempre que o parafuso bola está na mesma direção como as guias. Os medidores são o Chefe. Toleranz ist quase como zero.</p> <p>vn= Xin hãy nhìn luôn luôn là những con ốc tròn là trong cùng một hướng như hướng dẫn. Các thiết bị đo là trườg. Toleranz ist gần như bằng không.</p>	 <p>de= 1 Kugelgewinde können wir gerade mit einer Schraube lehren. Dafür benötigen Sie C1 Beispiel: 63x10 3,61 N 31x10 0.78N</p> <p>en= 1 ball screw we can just gage with a bolt. For that you need C1 Example: 63x10 3.61 N 31x10 0.78N</p> <p>pt= 1 parafuso bola podemos apenas calibrar com um parafuso. Para isso você precisa C1 Exemplo: 63x10 3,61 N 31x10 0.78N</p> <p>vn= 1 bóng vít, chúng tôi chỉ có thể Gage với một tia. Cho rằng bạn cần C1 Ví dụ: 63x10 3.61 N 31x10 0.78N</p>				
gezeichnet:	hp.Widmer	Datum: 27.08.11	education project	Kugelrollspindel	translate/en_ds/p_ct/vn_ro	origin: wiap kfkok
Aenderung:	an	Datum: 27.05.15	WIAP KFKOK	Ball Screw	r3	datei_wi_8_f_19_c1_r3_BallScrew02_
Aenderung:	control 2	Data:	Safenwil Schweiz	spear 2	<a href="http://www.wiap.ch">www.wiap.ch</a>	idee of / from HPW